



The L15 provides the industrial marketplace with a rugged high-resolution encoder in a compact size 15 servo package. Engineered with robust interpolative electronics, the L15 offers up to 40,640 cycles per turn. Ideal for space or weight limited applications, these compact encoders discount size without compromising performance.

The L15 encoder features 1/4-inch diameter stainless steel shaft and can accommodate up to 5 pounds radial or axial load. The L15 encoder package has field-proven ASIC electronics, sealed dual bearings and BEI's accurate code disk in an all metal housing to ensure ruggedness and reliability.

The L15 Incremental Encoder is available with the following certifications:



Mechanical Specifications

- Shaft Diameter:** 1/4 inch nominal
- Shaft Loading:** Up to 5 pounds axial and 5 pounds radial
- Shaft Runout:** 0.002 T.I.R. at midpoint of shaft
- Starting Torque at 25°C:** 0.20 in-oz (max)
- Bearings:** Sealed, instrument grade
- Shaft Material:** 416 stainless steel
- Bearing Housing:** Aluminum with protective finish
- Cover:** Drawn aluminum
- Bearing Life:** 1 X 10⁹ revs (10,000 hrs at 1500 RPM)
- Maximum RPM:** 5,000 RPM nominal (see Frequency Response, below)
- Moment of Inertia:** 1.0 X 10⁻⁴ oz-in-sec²
- Weight:** 6 oz (max)

Electrical Specifications

- Output Format:** 2 channels in quadrature, 1/2 cycle index gated with negative B channel
- Cycles Per Shaft Turn:** 24 to 40,640 (see Table 2 back page)
- Supply Voltage:** 5-28 VDC
- Current Requirements:** 100mA typical + output load 250mA (max), 150mA (max) with 28V/5
- Voltage/Output:**
 - 28V/V: Line Driver, 5-28VDC_{in}, V_{out} = V_{in}
 - 28V/5: Line Driver, 5-28VDC_{in}, V_{out} = 5VDC
 - 28V/OC: Open Collector, 5-28VDC_{in}, OC_{out}
- Protection Level:** Reverse, overvoltage and output short circuit
- Frequency Response:** 100kHz (non-interpolated), Up to 1 MHz interpolated
- Output Termination Pinouts:** see table on back page

Environmental Specifications

- Enclosure Rating:** NEMA 3. (IP53)
- Temperature:** Operating, 0° to 70° C; extended temperature testing available, -40° to 85° ; storage, -40° to 90° C
- Shock:** 50 G's for 11 msec duration (1/2 Sine)
- Vibration:** 20 to 2000 Hz @ 20 g's
- Humidity:** 98% RH non-condensing

NOTES & TABLES: All notes and tables referred to in the text can be found on the back of this page.

L15 Incremental Ordering Options FOR ASSISTANCE CALL 800-350-2727

Use this diagram, working from left to right to construct your model number (example: L15M-F25-256-ABZC-28V/V-SC18)

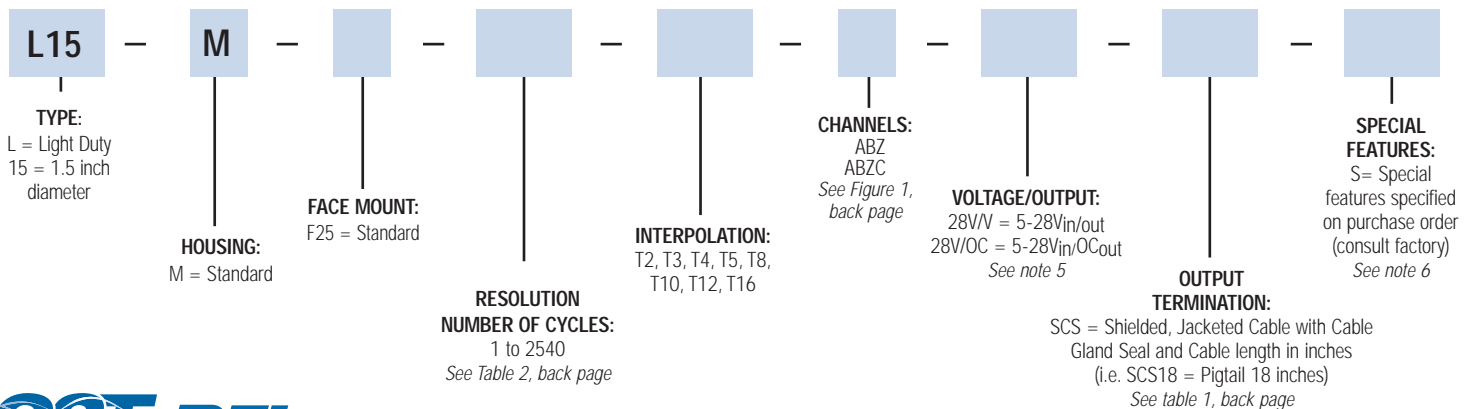

Notes

1. Mounting is usually done either using the D-style square flange mount, E- or G-style servo mounts, or one of the standard face mounts, F1 for example. Consult factory for additional face mount options.
2. The shaft seal is recommended in virtually all installations. The most common exceptions are applications requiring a very low starting torque or those requiring operation at both high temperature and high speed.
3. Non-standard index widths and multiple indices are available by special order. Consult factory.
4. Complementary outputs are recommended for use with line driver type (source/sink) outputs. When used with differential receivers, this combination provides a high degree of noise immunity.
5. **Output IC's:** Output IC's are available as either Line Driver (LD) or NPN Open Collector (OC) types. Open Collectors require pull-up resistors, resulting in higher output source impedance (sink impedance is similar to that of line drivers). In general, use of a Line Driver style output is recommended. Line Drivers source or sink current and their lower impedance mean better noise immunity and faster switching times. **Warning:** Do not connect any line driver outputs directly to circuit common/OV, which may damage the driver. Unused outputs should be isolated and left floating. Our applications specialists would be pleased to discuss your system requirements and the compatibility of your receiving electronics with Line Driver type outputs.
- 28V/V: Multi-voltage Line Driver (7272*): 100 mA source/sink. Input voltage 5 to 28 VDC +/- 5% standard (Note: $V_{out} = V_{in}$). This driver is TTL compatible when used with 5 volt supply. Supply lines are protected against overvoltage to 60 volts and reverse voltage. Outputs are short circuit protected for one minute. Supply current is 120 mA typical (plus load current). This is the recommended replacement for 3904R and 7406R open collector outputs with internal pullup resistors. It is also a direct replacement for any 4469, 88C30, 8830 or 26LS31 line driver.
- 28V/5: Multi-voltage Line Driver (7272*): 100 mA source/sink. Input voltage 5 to 28 VDC +/- 5% standard, internally regulated with 5V (TTL compatible) logic out. Supply lines are protected against overvoltage to 60 volts and reverse voltage. Outputs are short circuit protected for one minute. Supply current is 90 mA typical (plus load current). **Note:** Limit encoder load to 2.5W max at ambient. Example at 12 VDC: $2.5W / (+12VDC \text{ minus } +5VDC) = 357 \text{ mA}$ total allowed current. Consult factory for your specific requirements.
- 15V/V: Multi-voltage Line Driver (4469*): 100 mA source/sink. Input voltage 5 to 15 VDC +/- 5% standard (Note: $V_{out} = V_{in}$). TTL compatible when used with 5 volt supply. Supply lines are protected against overvoltage to 60 volts and reverse voltage. Outputs are short circuit protected for one minute. Supply current is 90 mA typical (plus load current). This is a direct replacement for the 4469 Line Driver.
- 28V/OC: NPN Open Collector (3904*, 7273*). Current sink of 80 mA max. Current sourced by external pull-up resistor. Output can be pulled up to voltage other than supply voltage (30 V max). Input voltage 5 to 28 VDC +/- 5% standard. Supply current is 120 mA typical. This replaces prior IC's with designations of 3904, 7406, 3302, 681 and 689.
- 5V/OCR, 15V/OCR, 24V/OCR: Open Collector (3904R*, 7406R*, 7273R*): Current sink of 70 mA max. Includes internal pull-ups sized at approximately 100 ohms/volt. Max current source is 10 mA. Supply current is 100 mA typical, 120 mA with internal pull-ups. The 5V/OCR, 15V/OCR and 24V/OCR are often replaced by the 28V/V in system upgrades.
6. Special -S at the end of the model number is used to define a variety of non-standard features such as special shaft lengths, voltage options, or special testing. Please consult the factory to discuss your special requirements.
7. Higher frequency response may be available. Please consult with the factory.
8. Extended temperature ratings are available in the following ranges: -40 to 70°C, -40 to 85°C, -20 to 105°C and -40 to 105°C depending on the particular model. Some models can operate down to -55°C. Extended temperature ranges can affect other performance factors. Consult with factory for more specific information.

* Products manufactured prior to April 2007 used the line driver IC number instead of voltage output in model number.

Tables

Table 1— Output Functions		Table 2— L15 Disc Resolutions				
COLOR	FUNCTION	(Other resolutions and interpolation options available—consult factory.)				
RED	+V (SUPPLY)	24	50	100	200	256
BLK	0 V (COMMON)	300	360	400	500	
YEL	A	512	625	900	1000	
WHT/YEL	\bar{A}	1024	1200	1250	1440	
BLU	B	1800	2000	2048		
WHT/BLU	\bar{B}	2500	2540			
ORN	Z					
WHT/ORN	\bar{Z}					
BARE	SHIELD DRAIN					

Figure 1 Output Waveforms

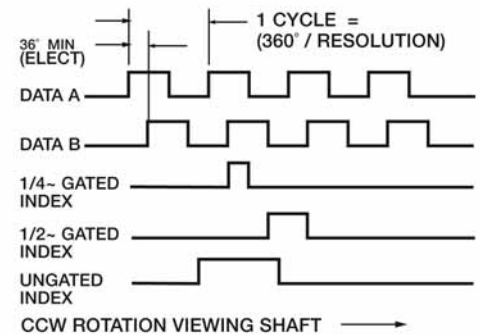

Dimensions

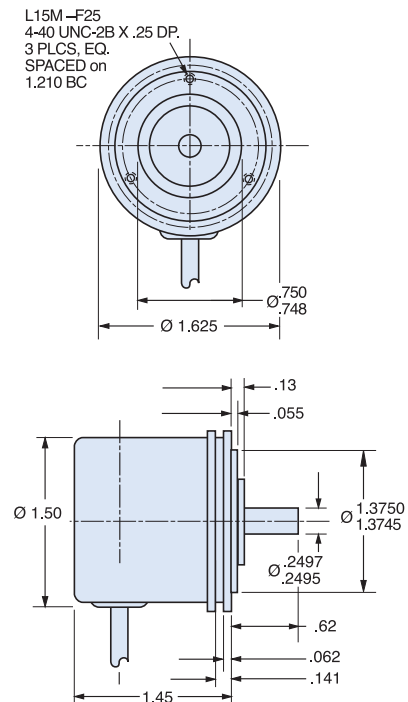

TOLERANCES: .XX=±0.02, .XXX=±0.005



These commodities, technology or software if exported from the United States must be in accordance with the Bureau of Industry, and Security, Export Administration regulations. Diversion contrary to U.S. law is prohibited.